

## M-110EH-30 Electric-Hydraulic Laboratory Microfluidizer Processor for Continuous High Shear Fluid Processing

### M-110EH-30 Microfluidizer® Processor, Standard and Explosion-proof

#### Recommended for:

- Particle Size Reduction for Submicron and Nano-sized particles
- Deagglomeration
- Cell Disruption
- Immiscible Liquid Emulsions
- Solid-in-Liquid Suspensions
- Liposomes

The M-110EH-30 has been designed to reliably achieve continuous operating pressures to 30,000 psi. The processor maximizes the energy-per-unit fluid volume, resulting in uniform submicron particle and droplet sizes.

Utilizing Microfluidics' fixed geometry diamond interaction chamber technology, and a ceramic (Zirconia) plunger, the M-110EH-30 is capable of processing a wide variety of fluids such as simple oil-in-water emulsions, solids-in-liquid suspensions, and cell disruptions, including the most difficult yeasts and plant cells, in 1-2 passes. What's more, the process is repeatable and is guaranteed to scaleup to pilot and/or production volumes.



### The M-110EH-30 Microfluidizer processor combines superior, scalable results with easy handling and clean-in-place

- Process pressure to 30,000 psi (2,070 bar)
- Flow rates to 320 ml/min at 30,000 psi
- Guaranteed scaleup to pilot and/or production
- Patented, wear resistant, diamond interaction chamber - no moving parts
- On-board heat exchanger for consistent discharge product temperature
- Ceramic (Zirconia) plunger for extended seal life
- Designed for clean-in-place with no disassembly required
- Available with steam-in-place (SIP) option
- Available explosion-proof option
- CE compliant (Europe)

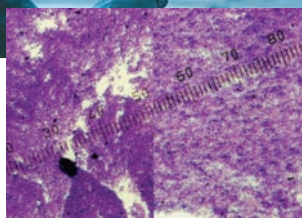

Before processing After processing

Along with other uses the patented Microfluidizer processor produces high-yield cell disruption with easy recovery

# Operating Principle

The M-110EH-30 contains an on-board 5 horsepower (3.7 kw) electric-hydraulic module that powers a single acting intensifier pump. The intensifier pump amplifies the hydraulic pressure to the selected level which, in turn, imparts that pressure to the product stream. Process pressures ranging from 2,500 to 30,000 psi may be selected with the simple turn of a knob.

The intensifier pump is designed to supply the desired pressure at a constant rate to the product stream. As the pump travels through its pressure stroke, it drives the product at constant pressure through the interaction chamber. Within the chamber are specially designed fixed-geometry micro-channels through which the product stream will accelerate to high velocities, creating high shear and impact forces that bring about the desired results as the high velocity product stream impinges on itself and on wear-resistant surfaces.

As the intensifier pump completes its pressure stroke, it reverses direction and draws in a new volume of product. At the end of the intake stroke, it reverses direction and again drives the product at constant pressure, repeating the process.

Upon exiting the interaction chamber, the product flows through an on-board heat exchanger which regulates the product to a desired temperature. At this point the product may be recirculated through the system for further processing or directed externally to the next step in the process.



A WHOLLY OWNED  
SUBSIDIARY OF  
**MFIC**  
CORPORATION

30 Ossipee Road, P.O. Box 9101  
Newton, MA 02464-9101 USA  
Tel: 1-800-370-5452 or: 617-969-5452  
Fax: 617-965-1213  
e-mail: [mixinginfo@mfics.com](mailto:mixinginfo@mfics.com)  
[www.microfluidicscorp.com](http://www.microfluidicscorp.com)

## M-110EH-30 Specifications

Pressure Range	up to 30,000 psi (2070 bar)
Flow Rate	up to 320 ml/min (optional 450 ml/min @ 25,000 psi)
Maximum Feed Temperature	165°F (75°C)
Holdup Volume	100 ml
Utility Requirements:	
• Electrical	3 phase 60 Hz service, 208/230/460V, 5 HP (3.7 KW) (50 Hz European standard available)
• Compressed Air	1 SCFM @ 50 psi (3.4 bar) with 35°F (2°C) max. dewpoint
• Hydraulic Oil Heat Exchanger Cooling Water	2.5 gpm (9.5 lpm) minimum @ 85°F (29°C) max.
• Product Outlet Heat Exchanger Cooling Water	5 gpm (18.9 lpm) @ 65°F (16°C)
Minimum Sample Size	120 ml
Dimensions	33"L x 34"W x 58"H (84 x 87 x 148 cm)
Weight	450 lbs. (205 kg)

## M-110EH-30 Standard Features

- Diamond interaction chamber with ceramic Auxiliary Processing Module (APM)
- Ceramic (Zirconia) plunger for extended seal life
- Stainless steel enclosure
- Electric-hydraulic power unit
- Gauges for measuring process pressure, hydraulic drive pressure, and hydraulic oil level and temperature
- Self-contained unit, mounted on locking casters for portability
- Flow rates to 320 ml/min @ 30,000 psi
- Minimum sample sizes as small as 120 ml
- Feed temperature to 165°F (75°C)
- TEFC (totally enclosed fan cooled) motor, starter, controls and power cord

## M-110EH-30 Available Options

- 2 liter reservoir
- 2 liter pressure-type reservoir
- Sanitary flush diaphragm pressure transducer with digital readout
- On-board air compressor for air switch activation
- Interaction Chamber cooling bath
- Explosion-proof design
- 2 gallon pressure-type feed tank
- Solvent seal quench system for 450 ml/min flow rate at 25,000 psi
- Additional interaction chamber set
- Steam sterility (or hot water) package

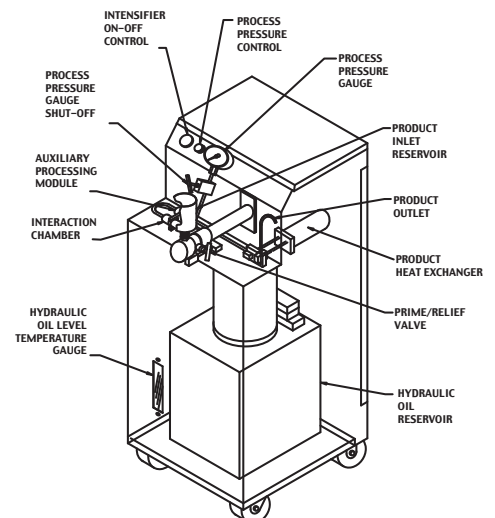

European Office  
Edisonstr.15  
68623 Lampertheim, Germany  
Tel: +49 (0) 6206-503-700  
Fax: +49 (0) 6206-503-705